

Head-mounted Temperature Transmitter TH01/TH01-Ex

Programmable,
Pt 100 (RTD), thermocouples,
electrically isolated

■ Parameter setting / configuration without the need for special software or drivers:

- Various parameter setting programs
- Device Management Tools:
DSV401 (SMART VISION), AMS, ...
- Hand-held terminals DHH691 (691 HT),
STT04, HC275, HC375, ...

■ Input

- Resistance thermometers (2-wire, 3-wire, 4-wire)
- Thermocouples
- Resistance remote signalling units (0...5000 Ω)
- Voltages, mV (-125...+1200 mV)

■ Output

- 2-wire technique
- 4...20 mA

■ Electrical isolation (I/O)

■ Continuous sensor and self-monitoring

- Parameter saved permanently in EEPROM
- Wire break monitoring in acc. with NAMUR NE 89

■ Substitution strategy in case of error (NE 43)

■ Approvals for explosion protection

- Intrinsically safe
 Ex II 2 (1) G EEx [ia] ib IIC T6, mount in zone 1

■ EMC acc. to EN 50082-2 and NE 21

■ 3 years warranty



Eco Message:
SW vendor independent
No DD drivers required

Technical data

Output

Output signal (temperature linear)

4...20 mA

Current consumption

< 3.6 mA

Maximum output current

23.6 mA

Parameterizable current error signal

Default value 3.6...23.6 mA

Damping

$t_{63} = 0...30$ s

Input

Resistance

Resistance thermometer (IEC 751¹⁾, JIS²⁾, MIL³⁾)

n · Pt 100/Ni 100 up to Pt 1000/Ni 1000; Cu⁴⁾
 (n = 0.1; 0.2; 0.5; 1; 1.2; 2; 3...10)
 Min. measuring span 15 K/50 K

Resistance

0...500 Ω/0...5000 Ω
 Min. measuring span 5 Ω/50 Ω

Maximum line resistance (R_w) per core

2-, 3-, 4-wire 7.5 Ω, 10 Ω, 50 Ω

Measuring current

300 μA

Sensor short-circuit

< 5 Ω (for RTD)

Sensor break (temperature/resistance measurement 2-, 3-, 4-wire)

Measuring range 0... 500 Ω > 530 Ω
 Measuring range 0...5000 Ω > 5.3 kΩ

Sensor wire break monitoring in accordance with NAMUR NE 89

Sensor wire break detection
 3-wire resistance measurement > 35 Ω
 4-wire resistance measurement > 3.7 kΩ

Input filter

50/60 Hz

Input resistance

> 10 MΩ

Thermocouples

Types

B, C, D, E, J, K, L, N, R, S, T, U

Voltages

-125 mV...+ 125 mV
 -125 mV...+1200 mV

Minimum measuring span

2 mV/50 mV

Sensor wire break monitoring in accordance with NAMUR NE 89

Pulsed with 1 μA outside of the measuring interval
 Monitoring disconnectible
 Thermocouple measurement > 5 kΩ
 Voltage measurement > 5 kΩ

Input filter

50/60 Hz

Internal reference junction

Pt 100, via software switchable (no jumper necessary)

Standard	Input element		Measuring range	Min. measuring span
		Sensor		
IEC 584-1		Thermocouple type B	0...+1820 °C (+432...+3308 °F)	264 °C (507 °F)
		Thermocouple type E	-270...+1000 °C (-454...+1832 °F)	30 °C (86 °F)
		Thermocouple type J	-210...+1200 °C (-346...+2192 °F)	37 °C (98 °F)
		Thermocouple type K	-270...+1372 °C (-454...+2502 °F)	54 °C (129 °F)
		Thermocouple type R	- 50...+1767 °C (- 58...+3213 °F)	171 °C (339 °F)
		Thermocouple type S	- 50...+1767 °C (- 58...+3213 °F)	193 °C (379 °F)
		Thermocouple type T	-270...+ 400 °C (-454...+ 752 °F)	50 °C (122 °F)
		Thermocouple type N	-270...+1300 °C (-454...+2372 °F)	61 °C (141 °F)
DIN 43710		Thermocouple type L	-200...+ 900 °C (-328...+1652 °F)	36 °C (96 °F)
		Thermocouple type U	-200...+ 600 °C (-328...+1112 °F)	40 °C (104 °F)
IEC 751 ¹⁾ ; JIS ²⁾ ; MIL ³⁾ 2-, 3- and 4-wire		Resistance thermometer Pt 100	-200...+ 850 °C (-328...+1562 °F)	15 °C (59 °F)
		Resistance thermometer Pt 1000	-200...+ 850 °C (-328...+1562 °F)	50 °C (122 °F)
DIN 43760 ⁵⁾ 2-, 3- and 4-wire		Resistance thermometer Ni 100	- 60...+ 250 °C (- 76...+ 482 °F)	8 °C (46 °F)
		Resistance thermometer Ni 500	- 60...+ 250 °C (- 76...+ 482 °F)	15 °C (59 °F)
Resistance	Ω		0...500 Ω/0...5000 Ω	5 Ω/50 Ω
Voltage	mV		-125 mV...+ 125 mV	2 mV
			-125 mV...+1200 mV	50 mV

¹⁾ IEC 751 a = 0.00385

²⁾ JIS C1604-81 a = 0.003916

³⁾ MIL-T24388 a = 0.003920

⁴⁾ Cu acc. SAMA, RC21-4-1966 a = 0.004260

⁵⁾ DIN 43760 a = 0.006180

Power supply (poling-protected)

Supply voltage

Non-Ex-application $U_s = 9...30$ V DC
 For Ex-Application, max. $U_i = 9...29.4$ V DC
 2-wire methode: power supply wires = signal wires

Influence of supply voltage

< 0.05 %/10 V

Maximum residual ripple

≤ 1 % U_s (< 500 Hz)

Power demand of indicators (only with AGLHD head)
 (Power demand of transmitter and indicator have to be added)

ProMeter

$U_{sd} = 2.9$ V DC

Maximum load

$$R(k\Omega) = \frac{(U_{smax} - U_{smin})}{22}$$

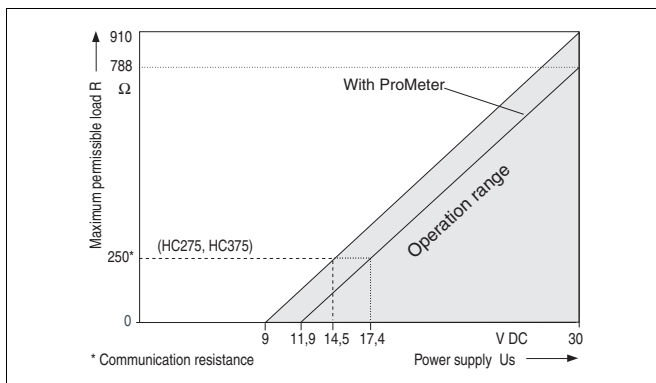

General characteristics

Output signal refreshment rate

Pt 100 0.4 s (Input signal change < 0.25 K/s)
 Thermocouples 0.2 s (Input signal change < 2.5 K/s)

Vibration resistance

Vibration in operation 2 g acc. to DIN IEC 68T.2-6
 Resistance to shock acc. to DIN IEC 68T.2-27

Electrical isolation (I/O)

1.5 kV AC (60 s)

Long-term stability

≤ 0.05 % or 0.1 K per year (whichever value is greater)

Environment conditions

Ambient temperature range

-40...+85 °C

Transport and storage temperature

-40...+100 °C

Relative humidity

< 100 % (100 % humidity with isolated terminals only)

Condensation

Permitted

Mechanical construction

Dimensions

See dimensional drawing

Weight

55 g

Housing material

Polycarbonat
 black (Non-Ex-type)
 blue (Ex-type)

Electrical connection

Terminals, pluggable

2.5 mm², screw terminals (stainless steel screws)

Characteristics at rated conditions

According to IEC 770 (related to 25 °C)¹⁾

Maximum measured error

Pt 100	≤ 0.1 % or ≤ 0.20 K (whichever value is greater)
Thermocouples	≤ 0.1 % or ≤ 0.5 K (whichever value is greater)
Linear resistance 500 Ω/5000 Ω	≤ 0.1 % or 80 mΩ/700 mΩ (whichever value is greater)
Linear voltage 120 mV/1200 mV	≤ 0.1 % or 40 μV/100 μV (whichever value is greater)

Additional influence of the internal reference junction

Pt 100 DIN IEC 751 Kl. B

Influences

Influence of ambient temperature acc. to IEC 68-2-2

0.08 % / 10 K

¹⁾ Percentage related to set measuring span
 Specified values corresponds to 3 σ (Gaussian normal distribution)

Explosion protection

Intrinsically safe

Zone 1

Marking
 EC-Type-Examination certificate
 Temperature class T6/T5/T4

II 2 (1) G EEx [ia] ib IIC T6
 PTB 03 ATEX 2083 X
 50 °C/65 °C/85 °C

Supply circuit	Output [ib]	Input [ia]
Max. voltage	$U_i = 29.4 \text{ V}$	$U_o = 5.6 \text{ V}$
Short-circuit current	$I_i = 130 \text{ mA}$	$I_o = 1.5 \text{ mA}$
Max. power	$P_i = 0.8 \text{ W}$	$P_o = 20 \text{ mW}$
Internal inductance	$L_i = 220 \text{ }\mu\text{H}$	$L_o = 1 \text{ mH}$
Internal capacitance	$C_i = 15 \text{ nF}$	$C_o = 1.55 \text{ }\mu\text{F}$

Electromagnetic compatibility (EMC)

Pt 100: measuring range 0...100 °C

Type of test	Degree	Influence	IEC
Burst to signal/ data lines	3 kV	< 0.1 %	1000-4-4
Static discharge Contact plate (indirect) Terminals for supply ¹⁾ Terminals for sensors ¹⁾	8 kV 6 kV 4 kV	no influence no influence no influence	1000-4-2
Radiated field 80 MHz...1 GHz	10 V/m	< 1.0 %	1000-4-3
Coupling 150 kHz - 80 MHz	10 V	< 1.0 %	1000-4-6
Surge: asymmetrisch symmetrisch	1 kV 0.5 kV	< 1 % < 1 %	1000-4-5

According to NAMUR NE 21 recommendation.

In case of an input signal change > 0.25 K/s for Pt100 or > 2.5 K/s for thermocouples a measured value plausibility check is performed.

¹⁾ Air discharge (at 1 mm distance)

Connection diagram

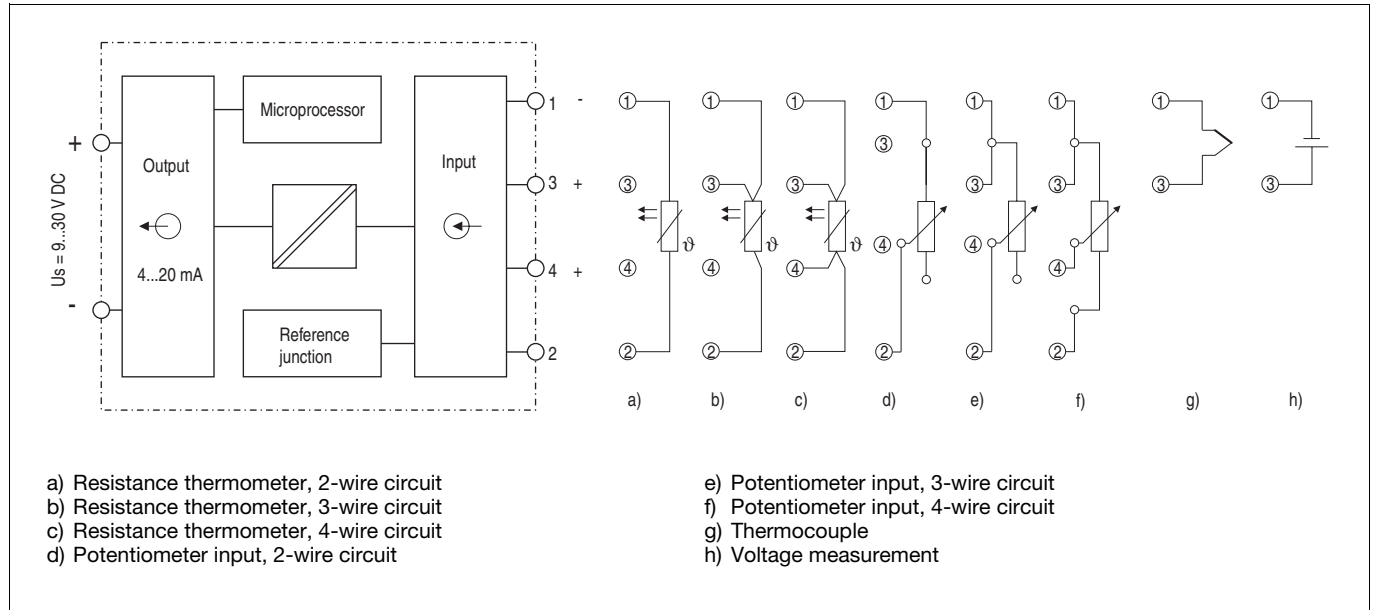

Dimensional drawings transmitter (dimensions in mm/inches)

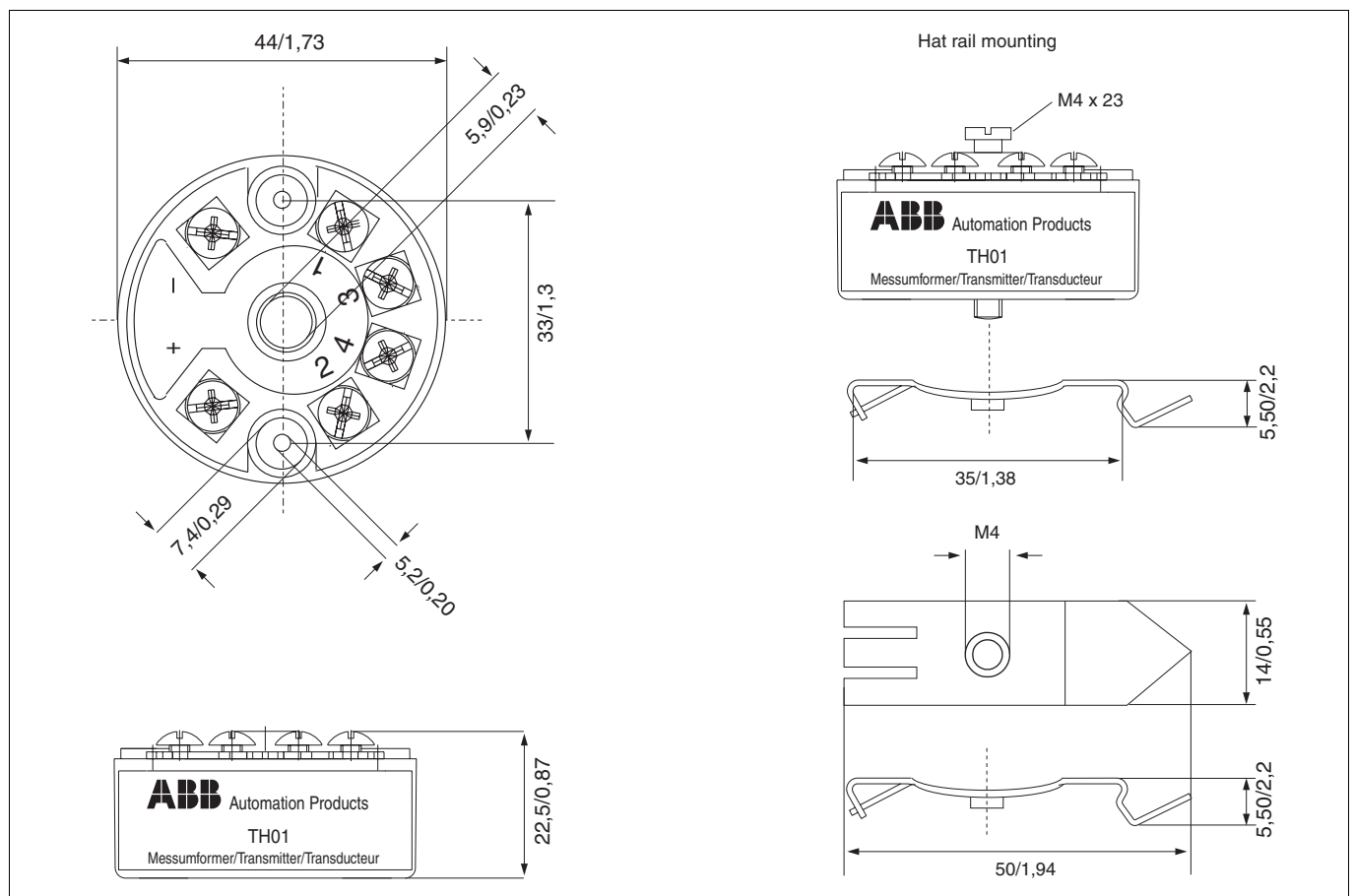

Programming:

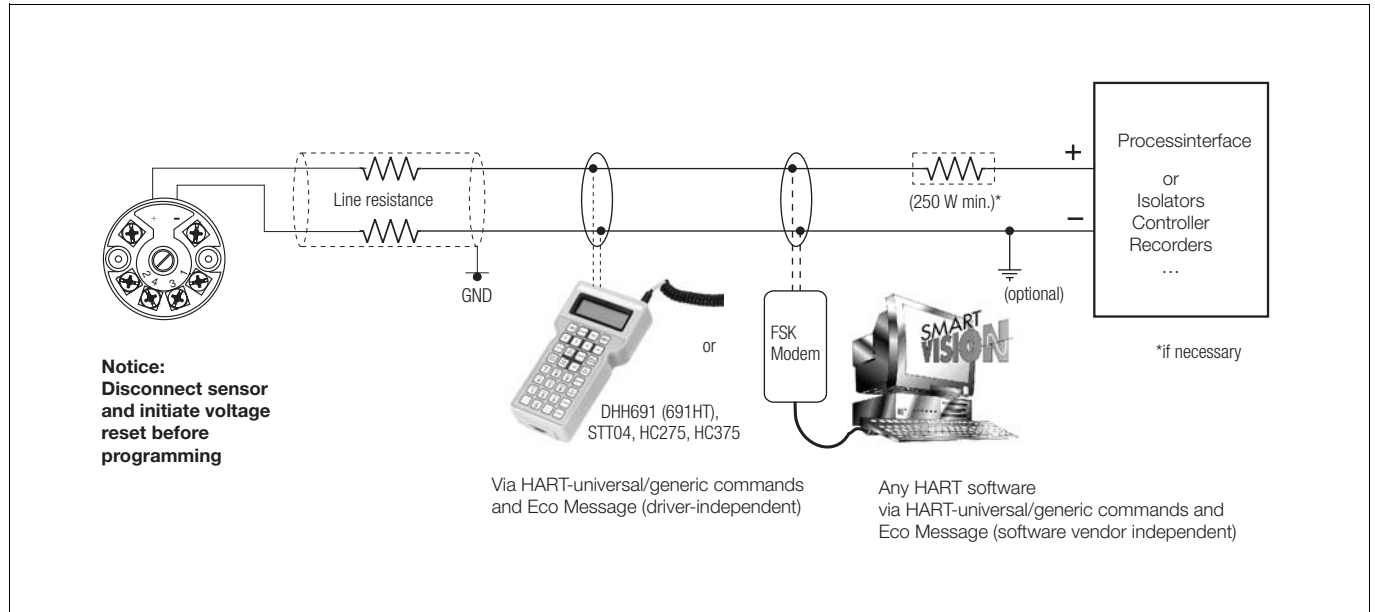

The for all sensor types useable TH01/101 temperature transmitter series is via the new Eco-message-method and the HART-generic/universal driver regarding all transmitter function programmable.

“Easy Configuration Message” (Eco Message)

The recently invented Eco Message method (patent pending) offers programming of ABB temperature transmitters over the entire functional scope, independently of the respective device driver.

So far, programming of all transmitter functions has always required the implementation of the respective device-specific driver compatible with the programming system or software.

Examples:

- Programming via hand-held terminal
 respective device description driver
- FDT/DTM technology
 respective DTM driver
- PDM technology
 respective PDM driver
- Cornerstone Software
 respective Cornerstone driver
- DSV401 (SMART VISION)
 respective SMART VISION driver (Applet or DTM)

**Notice: TH01/101 – No HART device
 Device is not HART conform**

With the generic (universal) drivers existing in the different programming systems or programs the temperature transmitters have only been programmable to a limited extent regarding the measuring range, the damping, the temperature unit and the additional information/message parameters.

Selecting the sensor type or adapting the sensor circuitry, e. g. changing over from 4-wire to 2-wire or 3-wire Pt100 RTDs, has always required a device-specific driver.

Often in case of using a Hand-held terminal is it not possible to load the device-specific driver self.

In another cases the respective compatible device-specific drivers have not been available for special programming systems/programs.

With the HART-generic/universal driver of any programming system or software and Eco Message it is now possible to program all functions of the ABB temperature transmitters of the “TH...” series, independently of a specific device driver.

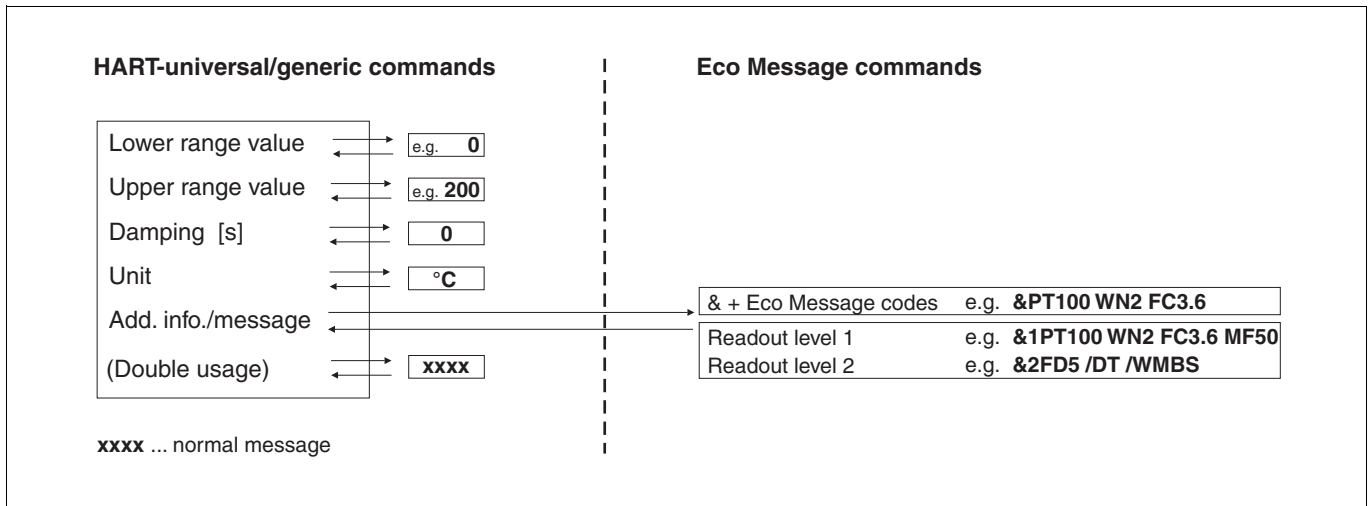

Description of the Eco Message method

The principle of the Eco Message method is based on the double usage of the universal Additional information/message parameter. When receiving an Additional information/message string the transmitter recognizes whether or not this is a standard information/message or an Eco Message marked by a preceding “&” character.

An Eco Message string consists of the leading “&” directly followed by the parameter code (max. 31 characters). Several parameter codes are separated by spaces.

As can be seen in the code table, a specific code has been defined for every parameter or parameter value that, so far, could not be set by a universal driver. Now you can e.g. change the Pt 100 sensor circuitry from 4-wire to 3-wire via Eco Message and universal driver by using the string “&WN3”. In principle, the code names are easy to remember, since they have been derived from the English parameter designations.

Regarding the read-out of the transmitter data it must be taken into account that it is not possible to indicate all coded parameters in the universal Additional information/message parameter at the same time, due to the limited string length of 31 characters. For this reason the coded parameters are organized in two groups and assigned to one of the two read-out levels.

Prior to sending the read-out command it must be determined which coded data is to be read out and indicated as the Additional information/message string.

All main parameters are arranged on read-out level 1. Reading out this level will cover approximately 95 % of the possible applications. Only some rarely used special parameters have been assigned to read-out level 2 (see code table).

In the standard delivery state the transmitters of the TH01/101 series are always set to read-out level 1.

Sending the string “&2” via Additional information/message parameter causes that the coded Eco Message parameters of read-out level 2 will be read as the Additional information/message string when the next read-out takes place.

As long as no new read-out level is specified, the transmitter remains on its last specified read-out level.

In order to illustrate programming through the Eco Message method several examples are provided under the code table.

Parameter settings

Parameters	ECO Message param. codes	Additional code value	Comment/Description	Read-out level	
The following codes will set the respective parameters, provided that they are sent to the transmitter in an additional information / message string starting with the character "&" + code(s) (see the example).					
RTD-Pt IEC a=.0385	PT	100...1000		1	
RTD-Pt JIS a=.03916	PJ	steps of or 10		1	
RTD-Pt MIL a=.03920	PM	100 20		1	
RTD-Ni DIN a=.0618	NI	50		1	
RTD-Cu	CU	120		1	
Linear resistance measurmt.	RL		progr. meas. range ≤ 0...500 ohms, (low range) short-circuit monitoring autom. off ¹⁾	1	
Linear resistance measurmt.	RH		progr. meas. range ≤ 0...5 Kohms, (high range), short-circuit monitoring autom. off ¹⁾	1	
Type of RTD circuitry	WN	2-wire, 3-wire or 4-wire	only for RTD, with RTD programming, without indic. autom. 2-wire or WN2 active	1	
2-wire feed line resistance	WR	0.00...15.00	optionally only for RTD 2-wire circuit or if WN2 code has been used before	1	
Thermocouple Type C	TC	1...10	internal reference junction or CI is always autom. active, without additional programming	1	
Thermocouple Type D	TD	No. of series-connected thermocouples without No.: always 1	internal reference junction or CI is always autom. active, without additional programming	1	
Thermocouple Type E	TE		internal reference junction or CI is always autom. active, without additional programming	1	
Thermocouple Type J	TJ		internal reference junction or CI is always autom. active, without additional programming	1	
Thermocouple Type K	TK		internal reference junction or CI is always autom. active, without additional programming	1	
Thermocouple Type L	TL		internal reference junction or CI is always autom. active, without additional programming	1	
Thermocouple Type N	TN		internal reference junction or CI is always active, without additional programming steps	1	
Thermocouple Type R	TR		internal reference junction or CI is always autom. active, without additional programming	1	
Thermocouple Type S	TS		internal reference junction or CI is always autom. active, without additional programming	1	
Thermocouple Type T	TT		internal reference junction or CI is always autom. active, without additional programming	1	
Thermocouple Type U	TU		internal reference junction or CI is always autom. active, without additional programming	1	
Thermocouple Type B	TB		no internal reference junction or CI is autom. active, additional programming required	1	
Internal reference junction	CI				1
Without reference junction	CN				1
Ext. reference junction [°C]	CE	-40.00...+85.00	indication of constant for ref. junct. temp. in the range -40...85°C/e.g. &CE50	1	
Linear voltage measurement	VL		progr. measuring range ≤ -125...125 mV, (low range) ¹⁾	1	
Linear voltage measurement	VH		progr. measuring range ≤ -125...1200 mV, (high range) ¹⁾	1	
Error signal [mA]	FC	3.60 .. 23.60		1	
Mains filter [Hz]	MF	50 or 60		1	
Error delay [sec]	FD	3...31	sensor and device error – delay for error signalling in seconds (e.g. loose contact detection – prevention of output signal step changes)	2	
Trim status (read-only)	/DT	W, D, WD	/DTW: 2-wire-feed line resistance programmed, /DTD: DA-trim programmed, /DTWD: both trimmings programmed, /DT: no trimming programmed	2	
Sensor line monitoring (read-only)	/WM	B, S, BS	/WMB: line break detection is active, /WMS: short-circuit monitoring is active, /WMSB: both are active	2	
Trimming reset	XCMFTRIM		DA converter trim and 2-wire feed line resistance are reset	none	
Selection of read-out level	&1		transmitting "&1" selects the parameters of read-out level 1 for the next read command.	1	
Selection of read-out level	&2		transmitting "&2" selects the parameters of read-out level 2 for the next read command	2	
Note: As can be seen in the examples, space characters must be entered between the individual parameter codes in the Eco Message string. Parameter programming is independent of the read-out level. Short-circuit monitoring is automatically switched off when the set RTD sensor contains ≤ 5 Ω					

¹⁾ Unit must be adapted for generic/universal commands

Setting parameters, examples

Examples for setting the Eco Message parameters via Additional information/message string

The examples listed below are based on the following standard parameter setting:

– Pt100, 4-wire, lower range value 0 °C, upper range value 100 °C, error current 22 mA, damping 0 s, mains filter 50 Hz, error delay 5 s, line break and short-circuit monitoring active, parameter read-out level 1 active or

&1PT100 WN4 FC22 MF50

(start of range, end of range, unit, damping, additional information/message (&+codes) are the universal/generic parameters of temperature transmitters)

Example 1 Parameter setting: Pt 100, 3-wire, error current 3.6 mA, mains filter 60 Hz

Write: Enter the following parameters in the additional information/message field and write to device: **&PT100 WN3 FC3.6 MF60**
Read: Make operator device / software read. ----> Result: **&1PT100 WN3 FC3.6 MF60**

Example 2 Parameter setting: Thermocouple Type K, internal RJ active (standard, need not be written)

Write: Enter the following parameters in the additional information/message field and write to device: **&TK**
Read: Make operator device / software read. ----> Result: **&1TK CI FC22 MF50**

Example 3 Parameter setting: Pt 100, 2-wire, 1.1 ohms sensor line resistance, error current 23.2 mA, error delay 3 s

Write: Enter the following parameters in the additional information/message field and write to device: **&PT100 WN2 WR1.1 FC23.2 FD3**
Read: Make operator device / software read. ----> Result: **&1PT100 WN2 WR1.1 FC23.2**

You have to change over to the second read level to be able to read its parameter values:

Write: Enter the following parameters in the additional information/message field and write to device: **&2**
Read: Make operator device / software read. ----> Result: **&2FD3 /DTW /WMBS**

Example 4 Parameter setting: Resistance measurement 0...5 kohms, 4-wire, error current 23 mA, error delay 7 s

(for resistance linear and voltage linear please observe the specifications and information in the table)

Write: Enter the following parameters in the additional information/message field and write to device: **&RH WN4 FC23 FD7**
Read: Make operator device / software read. ----> Result: **&1RH WN4 FC23**

You have to change over to the second read level to be able to read its parameter values:

Write: Enter the following parameters in the additional information/message field and write to device: **&2**
Read: Make operator device / software read. ----> Result: **&2FD7 /DT /WMB**

Display (Option, only in conjunction with AGLHD head)

ProMeter

- Programmable indicator
- loop-powered (4...20 mA)
- LC display:
 - 5 digits (± 1999), character height 7.6 mm, 7-segment
 - sign and variable decimal place
- 10-segment bargraph display (range-driven)
- 7 digits alphanumerical characters, height 6 mm, 14-segment
- Programmable display variables:
 - prozess value,
 - sensor value,
 - loop current,
 - percentage
- Password-protected programming access

Technical data

- Response time**
1.3 s
- Measuring error**
 $\pm 0.15 \%$
- Maximum current**
130 mA
- EMC**
EN 50082-2
- Temperature**
-20...+70 °C (-40...-20 °C, 70...85 °C without display)
- Relative humidity**
0...100 %, condensation permitted
- Mind limits of application

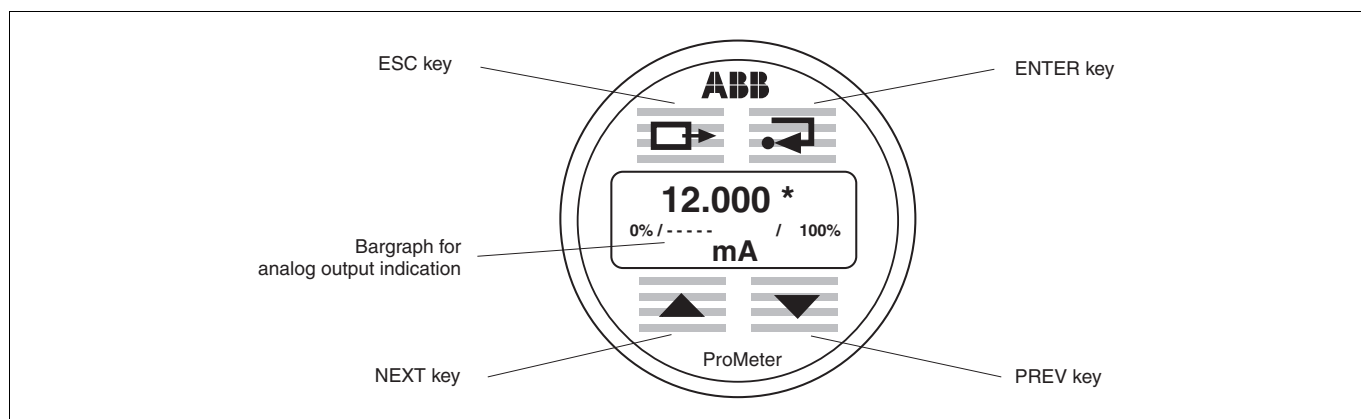

Configuration menu

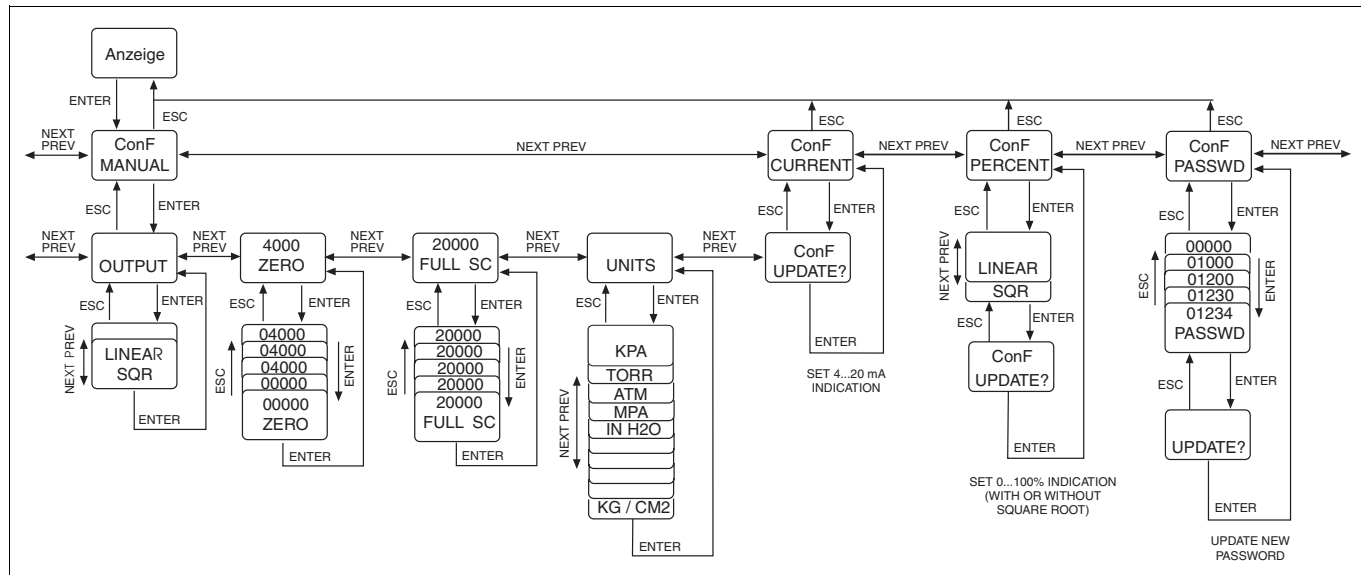

Note: When using the ProMeter for process value or sensor value indication, its zero and full scale programming must be in accordance with the transmitter temperature range or sensor range.

Dimensional drawings connection heads (dimensions in mm)

Type: BUZH, aluminium connection head IP 65

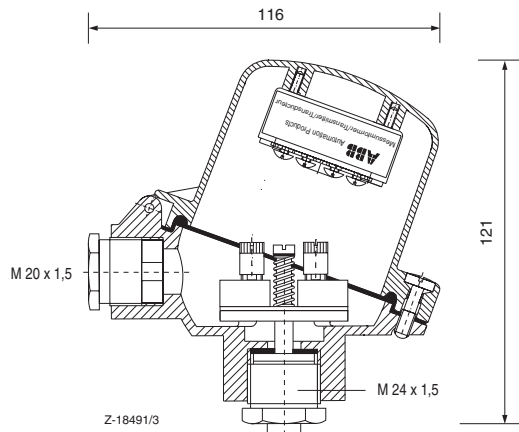

Type: BUSH, aluminium connection head IP 65

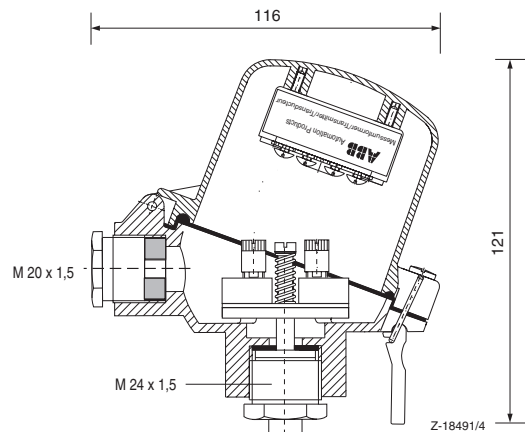

Type: AUZH, aluminium connection head IP 65

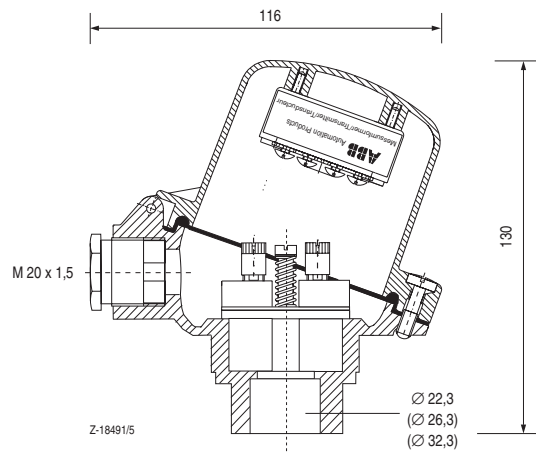

Type: AUSH, aluminium connection head IP 65

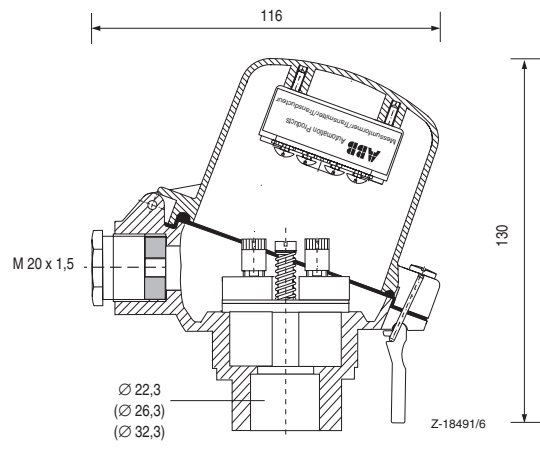

Type: BUKH-Ex polyamid/plastic connection head IP 65

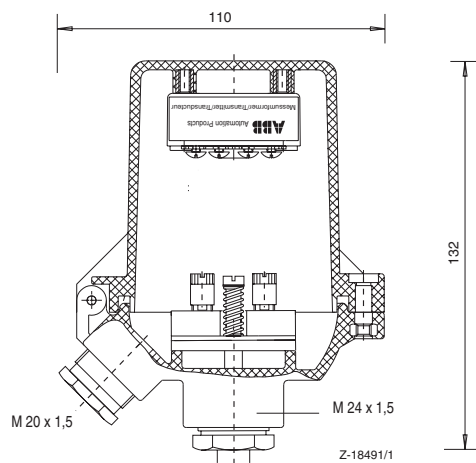

Type: DIN-B, aluminium connection head IP 65

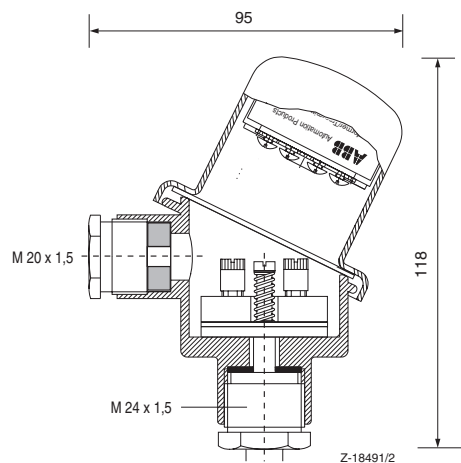

Dimensional drawings field housing (dimensions in mm)

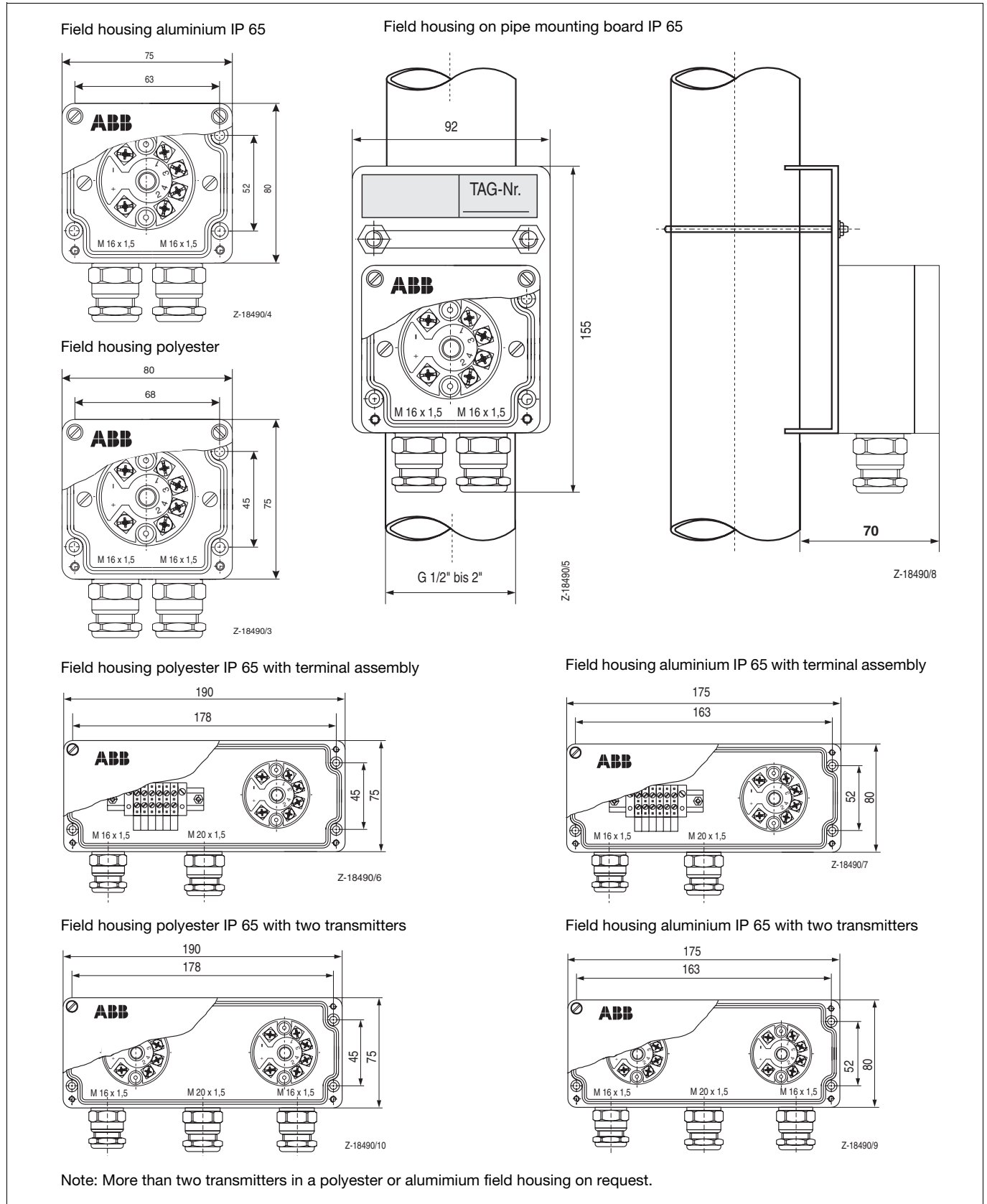

Ordering information

		Catalog No.					
TH01/TH01-Ex		V11508-					
TH01 (without Ex)		1					
Type of protection: intrinsically safe							
TH01-Ex ATEX Zone 1: II 2 (1) G EEx [ia]ib IIC T6		5					
Construction / display							
Module (h = 22.5 mm)			3				
Module (h = 22.5 mm) with sensor connecting line			1				
Module (h = 22.5 mm) with snap-on fixing			4				
Module (h = 27.5 mm) for mounting on measuring module			Z				
Module built into connection head or cover with sensor connecting line							
BUZH head			R				
BUSH head			P				
BUKH-Ex head			N				
Raised B-head cover			L				
B head (complete head with raised cover)			K				
AUZH head			V				
AUSH head			U				
AGLH head without display		1)	X				
AGLHD head with ProMeter (LCD display)		1)	D				
Attention: The sensor connecting lines correspond to the order for the type of sensor or its type of circuitry							
Module built into field housing:							
Aluminium field housing 80 x 75 x 57 mm, IP 65; 2 x M16 x 1.5			A				
Polyester field housing 75 x 80 x 55 mm, IP 65; 2 x M16 x 1.5			9				
Aluminium field housing 80 x 175 x 57 mm, IP 65; 1 x M16 x 1.5; 1 x M20 x 1.5 with separate terminal block			F				
Polyester field housing 75 x 190 x 55 mm, IP 65; 1 x M16 x 1.5; 1 x M20 x 1.5 with separate terminal block			E				
Note: Other field housings with more than one transmitter or especially for pipe mounting on request							
Programming							
Factory standard parameter Pt 100, 0...100 °C, 4 wire circuit, measuring range 0...100 °C, damping off, direct action characteristic overranging at sensor or device error (22 mA)			0				
Customer-specific parameter setting (questionnaire)			1				
Calibration certificates							
without			0				
2 point			1				
9 point			2				
Accessories							
		Catalog No.					
Universal programming set (hardware requirements)		see Data Sheet 10/63-6.71 EN					

1) Standard: Aluminium, metal-cable-screw-connection M20 x 1.5 EEx e;
 protective pipe connection M24 x 1.5 (optional M20 x 1.5; 1/2" NPT; 3/4" NPT)

The Industrial^{IT} wordmark and all mentioned product names in the form XXXXX^{IT} are registered or pending trademarks of ABB.

ABB has Sales & Customer Support expertise in over 100 countries worldwide.

www.abb.com

The Company's policy is one of continuous product improvement and the right is reserved to modify the information contained herein without notice.

Printed in the Fed. Rep. of Germany (04.04)

© ABB 2004



ABB Ltd.

Salterbeck Trading Estate
Workington, Cumbria, CA14 5DS
UK
Tel: +44(0)1946-830-611
Fax: +44(0)1946-832-661

ABB Inc.

125 E. County Line Road
Warminster, PA 18974
USA
Tel: +1 215-674-6000
Fax: +1 215-674-7183

ABB Automation Products GmbH

Borsigstr. 2
63755 Alzenau
Germany
Tel: +49 551 905-534
Fax: +49 551 905-555
CCC-support.deapr@de.abb.com