

Diaphragm Seals

Flange-Type Diaphragm Seals • Model 990.27

Chemical Seals

Service intended

Process industry diaphragm seal to combine with pressure gauges and transmitters.

Suitable for corrosive, contaminated, hot or viscous pressure media.

Design

DN ≤ 25/1": open flange with an internal diaphragm with contoured diaphragm bed

DN ≥ 40/1½": body with sealing face and flush diaphragm with contoured diaphragm bed

Process connection

Flanges DN 15, 20, 25, 40, 50, 80, 100, 125 per DIN or NPS ½", ¾", 1", 1½", 2", 3", 4", 5" per ASME

Pressure rating

see table (reverse side)

Suitable pressure ranges

25 mbar and up, depending on diaphragm size and process conditions

Standard features

Body (process connection)

Stainless steel 1.4571,
Flange DIN 2501, sealing face form D DIN 2526, or ASME B 16.5 RF 500 RMS

Diaphragm

Stainless steel 1.4571, welded to body

Capillary extension

Axial entry capillary of stainless steel 1.4571, welded to body
For DN 50/2" and larger: armoured, armour material stainless steel 1.4301

Standard extensions: 1, 1.6, 2.5, 4, 5, 6, 7, 8 m

Minimum curve radius: 50 mm

Armour material stainless steel 1.4301

Instrument connection

Stainless steel 1.4571, axial weld-in connection or adaptor G ½ female per EN 837-1 / 7.3.5, welded to capillary



Optional extras

Body (process connection)

- Sealing faces:
 - DIN 2526 form E, C; ASME B 16.5 RFSF
 - DIN 2512 groove and tongue; DIN 2513 projection and recess
 - ASME B 16.5 snap ring groove form RJF
- limited for special materials (please inquire)
- Flame proof throttle approved for Zone 0

Diaphragm

- Stainless steel 1.4435, 1.4541
- titanium; Hastelloy B2, C4, C276; Monel 400; nickel
- Inconel 600; Incoloy 825; tantalum
- Metal-bonded to flange body of 1.4571, suitable up to 400 °C
- Silver foil max. 150 °C
- Gold plating approx. 25 micron
- PTFE foil max. 150 °C ≤ +100 bar
- PFA coating max. 260 °C
- ECTFE coating max. 150 °C

Diaphragm seal with step-type diaphragm

- In critical diaphragm seal applications used in overpressure areas the use of the step-type diaphragm causes only minimal influence of temperature. Special features and available versions see technical information IN 00.13

Capillary extension

- Radial entry
- Custom extension lengths between 1 and 15 m
- Soft polyethylene armour

Instrument connection

- Adaptor with optional welding or pipe thread nipple
- Gauge adaptor G ½ female for directly mounted gauge
- Various adaptors for directly mounted transmitters
- Cooling tower for directly mounted gauge when fluid temperature > 100 °C

Flushing ring

- Stainless steel 1.4571, for flange per DIN DN 50 ... 125 or ASME 2" ... 5" (see data sheet CS 91.05)

Dimensions

Standard version

Version for $DN \leq 25/1''$

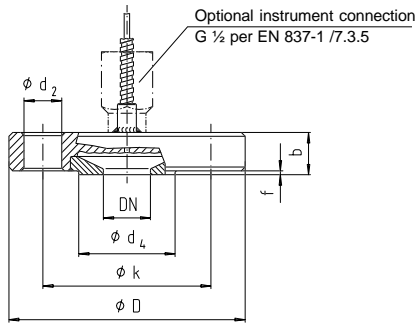

1387 987.01

Version for $DN \geq 40/1\frac{1}{2}''$

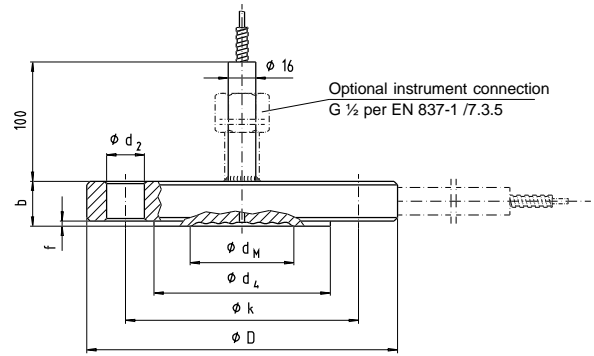

1387 979.01

Flange per DIN 2501

DN [mm]	PN [bar]	Dimensions [mm]								Weight [kg]
		d _M	D	b	d ₂	k	Raised portion			
							f	d ₄	x	
15	10/40	40	95	22	14	65	2	45	4	1.00
20	10/40	40	105	22	14	75	2	58	4	1.30
25	10/40	52	115	22	14	85	2	68	4	1.50
40	10/40	48	150	18	18	110	3	88	4	2.10
	63/100	48	170	26	22	125	3	88	4	4.00
	160	48	170	28	22	125	3	88	4	4.30
	250	48	185	34	26	135	3	88	4	6.30
50	10/40	59	165	20	18	125	3	102	4	3.30
	63	59	180	26	22	135	3	102	4	5.10
	100	59	195	28	26	145	3	102	4	6.50
	160	59	195	30	26	145	3	102	4	7.00
	250	59	200	38	26	150	3	102	8	9.30
80	10/16	89	200	20	18	160	3	138	8	4.90
	25/40	89	200	24	18	160	3	138	8	5.80
	63	89	215	28	22	170	3	138	8	7.90
	100	89	230	32	26	180	3	138	8	10.40
	160	89	230	36	26	180	3	138	8	11.70
	250	89	255	46	30	200	3	138	8	18.40
100	10/16	89	220	20	18	180	3	158	8	5.90
	25/40	89	235	24	22	190	3	162	8	8.10
	63	89	250	30	26	200	3	162	8	11.50
	100	89	265	36	30	210	3	162	8	15.50
	160	89	265	40	30	210	3	162	8	17.30
	250	89	300	54	33	235	3	162	8	29.90
125	10/16	124	250	22	18	210	3	188	8	8.40
	25/40	124	270	26	26	220	3	188	8	11.60
	63	124	295	34	30	240	3	188	8	14.70
	100	124	315	40	33	250	3	188	8	24.40
	160	124	315	44	33	250	3	188	8	26.90
	250	124	340	60	33	275	3	188	8	42.70

Effective diameter of diaphragm = d_M , Number of drill holes = x

Ordering information

Model / Size, pressure rating and applicable process connection / Material of wetted parts / Capillary extension length / Filling liquid / Instrument connection / Process conditions as per questionnaire

Specifications and dimensions given in this leaflet represent the state of engineering at the time of printing. Modifications may take place and materials specified may be replaced by others without prior notice.

Flange per ASME B 16.5

NPS [in.]	PN [class]	Dimensions [mm]								Weight [kg]
		d _M	D	b	d ₂	k	Raised portion			
							f	d ₄	x	
1/2	150	32	90	22	16	60.5	2	35	4	1.00
	300	40	95	22	16	66.5	2	35	4	1.00
3/4	150	40	100	22	16	70	2	43	4	1.10
	300	40	120	22	20	82.5	2	43	4	1.60
1	150	52	110	22	16	79.5	2	51	4	1.40
	300	52	125	22	20	89	2	51	4	1.70
1 1/2	150	48	130	22	16	98.5	2	73	4	1.60
	300	48	155	22	22	114.5	2	73	4	2.50
	600	48	155	29.5	22	114.5	7	73	4	3.30
	1500	48	180	39	30	124	7	73	4	5.90
	2500	48	205	51.5	33	146	7	73	4	10.40
2	150	59	150	20	20	120.5	1.6	92	4	2.70
	300	59	165	22.5	20	127	1.6	92	8	3.70
	600	59	165	32	20	127	6.4	92	8	5.70
	1500	59	215	45	26	165	6.4	92	8	13.20
	2500	59	235	57.5	30	171.5	6.4	92	8	19.80
3	150	89	190	24	20	152.5	1.6	127	4	5.30
	300	89	210	29	22	168.5	1.6	127	8	7.80
	600	89	210	38.5	22	168.5	6.4	127	8	11.00
	1500	89	270	54.5	33	203	6.4	127	8	24.50
	2500	89	305	73.5	36	228.5	6.4	127	8	42.70
4	150	89	230	24	20	190.5	1.6	158	8	7.70
	300	89	255	32	22	200	1.6	158	8	12.70
	400	89	255	41.5	26	200	6.4	158	8	17.40
	600	89	275	45	26	216	6.4	158	8	21.50
	900	89	295	51	32	235	6.4	158	8	27.70
	1500	89	310	60.5	36	241.5	6.4	158	8	37.00
2500	89	355	83	42	273	6.4	158	8	65.70	



WIKA Alexander Wiegand GmbH & Co. KG
 Alexander-Wiegand-Straße · 63911 Klingenberg
 ☎ (0 9372) 132-0 · ☎ (0 9372) 132-406/414
<http://www.wika.de> · E-mail: info@wika.de