

# Flanged Process Connection, Diaphragm Seals with Flush Diaphragm Model 990.27

WIKA Data Sheet DS 99.27

## Applications

- Chemical process industry
- Petrochemical industry
- Suitable for corrosive, highly viscous, crystallising or hot pressure media

## Special Features

- Flange with a flush welded diaphragm with contoured diaphragm bed
- Available for all standard dimensions and nominal diameters
- With special materials all wetted parts of the selected material

## Description

### Process connection

Flanges DN 25, 40, 50, 80, 100, 125 following EN 1092-1, sealing face form B1 or NPS 1", 1½", 2", 3", 4", 5" per ASME B 16.5, RF 125 ... 250 AA

### Pressure rating

See table (reverse side)

### Suitable pressure ranges

25 mbar and up, depending on diaphragm size and process conditions

### Material of wetted parts

Stainless steel 316L

### Instrument connection

Material stainless steel 316L, axial weld-in connection or adaptor G ½ female per EN 837-1, welded to capillary



Diaphragm Seal, Flanged Process Connection Model 990.27 with Pressure Gauge Model 232.50 NS 100

### Capillary extension

Axial entry capillary of stainless steel 1.4571, welded to body, armoured, armour material stainless steel 1.4301  
Standard extensions: 1, 1.6, 2.5, 4, 5, 6, 7, 8 m  
Minimum curve radius: 30 mm

## Optional extras

### Process connection

- Other flanged process connections on inquiry
- Sealing faces per EN 1092-1, form B2 or per ASME B 16.5, RF 125 AA, 500AA, RFSF; EN 1092-1 groove and tongue; projection and recess; ASME B 16.5 snap ring groove form RJF (limited for special materials, please inquire)
- Flame arrester approved for Zone 0

### Instrument connection

- Adaptor with optional welding or pipe thread nipple
- Gauge adaptor G ½ female for directly mounted gauge
- Various adaptors for directly mounted transmitters
- Cooling tower for directly mounted gauge when fluid temperature > 100 °C

### Material of wetted parts

- Stainless steel 1.4435, 1.4541, 1.4571, 1.4462, Monel 400, Hastelloy C276, Inconel 600, Incoloy 825, tantalum max. 400 °C
- Hastelloy B2, C4, C22 and nickel max. 260 °C (max. 400 °C on inquiry)
- Platinum, titanium, zircon max. 150 °C (max. 400 °C on inquiry)
- Silver foil max. 150 °C
- Stainless steel 316L with gold plating approx. 25 micron
- PTFE foil max. 260 °C ≤ 100 bar
- PFA coating max. 260 °C
- ECTFE (Halar®) coating max. 150 °C

### Capillary extension

- Custom extension lengths between 1 and 15 m
- Soft polyethylene or PTFE armour

### Flushing ring

- Stainless steel 316L, for flange DN 40 ... 125 per EN resp. NPS 1½" ... 5" per ASME (see data sheet AC 91.05)

## Dimensions in mm

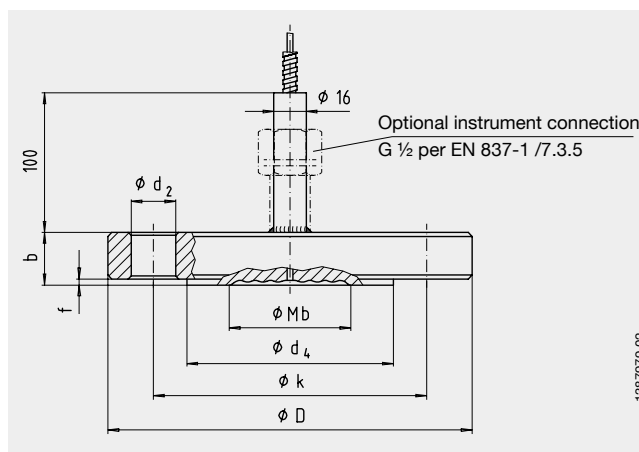

### Flange connection following EN 1092-1, form B1 / DIN 2501, form D

DN in mm	PN in bar	Dimensions in mm					Raised portion			Weight in kg
		Mb	D	b	d <sub>2</sub>	k	f	d <sub>4</sub>	x	
25	10/40	32	115	22	14	85	2	68	4	1.50
	63/100	25	140	24	18	100	2	68	4	2.50
40	10/40	48	150	18	18	110	2	88	4	2.10
	63/100	48	170	26	22	125	2	88	4	4.00
	160	48	170	28	22	125	2	88	4	4.30
	250	48	185	34	26	135	2	88	4	6.30
50	10/40	59	165	20	18	125	2	102	4	3.30
	63	59	180	26	22	135	2	102	4	5.10
	100	59	195	28	26	145	2	102	4	6.50
	160	59	195	30	26	145	2	102	4	7.00
	250	59	200	38	26	150	2	102	8	9.30
80	10/16	89	200	20	18	160	2	138	8	4.90
	25/40	89	200	24	18	160	2	138	8	5.80
	63	89	215	28	22	170	2	138	8	7.90
	100	89	230	32	26	180	2	138	8	10.40
	160	89	230	36	26	180	2	138	8	11.70
	250	89	255	46	30	200	2	138	8	18.40
100	10/16	89	220	20	18	180	2	158	8	5.90
	25/40	89	235	24	22	190	2	162	8	8.10
	63	89	250	30	26	200	2	162	8	11.50
	100	89	265	36	30	210	2	162	8	15.50
	160	89	265	40	30	210	2	162	8	17.30
	250	89	300	54	33	235	2	162	8	29.90
125	10/16	124	250	22	18	210	2	188	8	8.40
	25/40	124	270	26	26	220	2	188	8	11.60
	63	124	295	34	30	240	2	188	8	14.70
	100	124	315	40	33	250	2	188	8	24.40
	160	124	315	44	33	250	2	188	8	26.90
	250	124	340	60	33	275	2	188	8	42.70

Mb = effective diameter of diaphragm, x = number of drill holes

## Flange connection per ASME B 16.5, raised face

NPS	Class	Dimensions in mm					Raised portion			Weight in kg
		Mb	D	b	d <sub>2</sub>	k	f	d <sub>4</sub>	x	
<b>1"</b>	150	32	110	22	16	79.5	2	51	4	1.40
	300	32	125	22	20	89	2	51	4	1.70
<b>1½"</b>	150	48	130	22	16	98.5	2	73	4	1.60
	300	48	155	22	22	114.5	2	73	4	2.50
	600	48	155	29.5	22	114.5	7	73	4	3.30
	1500	48	180	39	30	124	7	73	4	5.90
	2500	48	205	51.5	33	146	7	73	4	10.40
<b>2"</b>	150	59	150	20	20	120.5	1.6	92	4	2.70
	300	59	165	22.5	20	127	1.6	92	8	3.70
	600	59	165	32	20	127	6.4	92	8	5.70
	1500	59	215	45	26	165	6.4	92	8	13.20
	2500	59	235	57.5	30	171.5	6.4	92	8	19.80
<b>3"</b>	150	89	190	24	20	152.5	1.6	127	4	5.30
	300	89	210	29	22	168.5	1.6	127	8	7.80
	600	89	210	38.5	22	168.5	6.4	127	8	11.00
	900	89	240	45	26	190.5	6.4	127	8	16.70
	1500	89	270	54.5	33	203	6.4	127	8	24.50
	2500	89	305	73.5	36	228.5	6.4	127	8	42.70
<b>4"</b>	150	89	230	24	20	190.5	1.6	158	8	7.70
	300	89	255	32	22	200	1.6	158	8	12.70
	400	89	255	41.5	26	200	6.4	158	8	17.40
	600	89	275	45	26	216	6.4	158	8	21.50
	900	89	295	51	32	235	6.4	158	8	27.70
	1500	89	310	60.5	36	241.5	6.4	158	8	37.00
	2500	89	355	83	42	273	6.4	158	8	65.70

Mb = effective diameter of diaphragm, x = number of drill holes

### Ordering information

Model / Process connection (standard, nominal size, pressure rating, sealing face) / Material of wetted parts / Instrument connection: directly combined or capillary extension, capillary length / Fill fluid / Pressure gauge model / Process conditions: application, process temperature max. and min., ambient temperature max. and min.

Modifications may take place and materials specified may be replaced by others without prior notice.  
Specifications and dimensions given in this leaflet represent the state of engineering at the time of printing.



**WIKAI Alexander Wiegand GmbH & Co. KG**  
Alexander-Wiegand-Straße 30  
63911 Klingenberg/Germany  
Phone (+49) 93 72/132-0  
Fax (+49) 93 72/132-406  
E-Mail [info@wika.de](mailto:info@wika.de)  
[www.wika.de](http://www.wika.de)