

UniTrans® Universal Transmitter for various applications Model UT-10 and UT-11

WIKA Data Sheet PE 86.01



Applications

- Process engineering
- Chemical engineering
- Plant construction
- Mechanical engineering

Special Features

- Scaleable measuring ranges via Turn down of up to 1:20
- Measuring range from 0 ... 5 mbar up to 0 ... 4,000 bar
- High measuring accuracy
- Fully welded, stainless steel diaphragm
- Multifunctional display



Fig. left Universal Transmitter UT-11
Fig. right Universal Transmitter UT-10

Description

Turn Down

With its maximal 1 : 20 Turn Down ratio the UniTrans can be used in many different applications. This turndown ratio eliminates the necessity of keeping several transmitters in stock; it is much easier to turn down the transmitter instead of changing transmitters (e.g. a 100 bar transmitter can be turned down to 5 bar).

High measuring accuracy

The internal, digital signal processing allows for high measuring accuracy at fast measuring rates and pressure ranges from 5 mbar to 4,000 bar.

Multifunctional display

The optional display can be adjusted mechanically and electronically, thus guaranteeing many display variations and an optimal reading from different directions. Bargraph and trend are permanently displayed.

Only a minor modification of the case is required in order to be able to read the display from above. All standard units can be displayed. Two further lines are available for entering additional text (e.g. min./max. values or temperature at the sensor).

With the easy-to-use menu, the user can set parameters such as language, unit, zero point, span or inverted signal.

The UniTrans also offers the possibility of a tank linearisation with up to 32 holding points.

Signal

The UniTrans is fed with an input power of 12 ... 36 DC V. The output signal is 4 ... 20 mA, 2-wire system. The user can program an inverted signal 20 ... 4 mA or damping (up to 40 seconds).

Specifications

Model UT-10, standard version / UT-11 flush diaphragm

Pressure ranges ^{1)*)}	bar	0,1 ²⁾	0.4	1.6	6	16	40	100	250	600
Over pressure safety	bar	10	2	10	35	80	80	200	500	1200
Burst pressure	bar	12	2.4	12	42	96	400	800	1200	2400 ⁴⁾
Pressure ranges ^{1)*)}		1000 ³⁾	1600 ³⁾	2500 ³⁾	4000 ³⁾					
Over pressure safety		1500	2000	3000	4400					
Burst pressure		3000	4000	5000	7000					
{Vacuum, gauge pressure, compound range, absolute pressure are available}										
¹⁾ Other measuring ranges (e. g. 4 bar) can be set via the respective Turn down. Even when the measuring range is present by us on (e. g. 4 bar) the standard range of (6 bar) can be set again by a reset.										
²⁾ Try capacitive ceramic sensor; additional wetted parts are ceramic and FPM/FKM {EPDM}										
³⁾ Only Model UT-10.										
⁴⁾ For model UT-11: the value specified in the table applies only when sealing is realised with the sealing ring underneath the hex. Otherwise max. 1500 bar applies.										
Materials		(other materials see WIKA diaphragm seal program)								
■ Wetted parts		Stainless steel (pressure ranges > 25 bar additional Elgiloy®)								
➢ Model UT-10		Stainless steel {Hastelloy C4}; O-ring: NBR ⁴⁾ {FPM/FKM or EPDM}								
➢ Model UT-11		Highly resistive, fibreglass-enforced plastic (PBT); {Aluminum}								
■ Case		Synthetic oil {Halocarbon oil for oxygen applications}								
Internal transmission fluid ⁵⁾		{Listed by FDA for Food & Beverage}								
⁴⁾ O-ring made of FPM/FKM {EPDM} for Model UT-11 with integrated cooling element.										
⁵⁾ Not for UT-10 with pressure ranges > 25 bar										
Power supply U _B	DC V	12 < U _B ≤ 36								
Signal output and maximum load R _A		4 ... 20 mA, 2-wire R _A ≤ (U _B - 12 V) / 0.023 A with R _A in Ohm and U _B in Volt								
Adjustability										
■ Zero Point	%	-2.5 ... 99								
■ Span		Turn down of 1 : 20 (1 : 2 for pressure ranges > 1000 bar)								
Internal measuring rate	Hz	100								
Accuracy ⁶⁾	% of span	≤ 0.1 (≤ 0.3 for pressure ranges > 1000 bar)								
⁶⁾ Including non-linearity, hysteresis, non-repeatability, zero point and full scale error (corresponds to error of measurement per IEC 61298-2). Adjusted in vertical mounting position with lower pressure connection.										
Behavior with Turn down (1 : k)										
■ Turn down of up to 1 : 5		No change of accuracy								
■ Turn down of 1 : 5 to 1 : 20		The accuracy must be multiplied by the factor (k / 5) [Calculation example for TD = 1 : 15] Accuracy = 0.1 x (15 / 5) = 0.3								
Non-linearity	% of span	≤ 0.05 (≤ 0.2 for pressure ranges > 1000 bar) (BFSL) according to IEC 61298-2								
1-year stability	% of span	≤ 0.1 (at reference conditions)								
Overall deviation	%	at +10 ... +40 °C (+50 ... +104 °F): ≤ 0.15 (≤ 0.6 for pressure ranges > 1000 bar)								
Permissible temperature of										
■ Medium [*])		-30 ... +105 °C (G 1 ½ up to 30 min 140°C at an ambient temperature of < 50 °C)								
		-30 ... +150 °C (G 1 according to EHEDG with cooling element)								
■ Ambience		-40 ... +85 °C (-20...+70 °C with display)				-40 ... +185 °F (-4...+158 °F with display)				
■ Storage		-40 ... +85 °C (-35...+80 °C with display)				-40 ... +185 °F (-31...+176°F with display)				
Compensated temp. range		-20 ... +80 °C				-4 ... +176 °F				
Temperature coefficients within compensated temp range		(the temperature related deviations in the range +10 ... +40 °C / +50 ... +104 °F included in the overall deviation)								
■ Mean TC of zero	% of span	≤ 0.1 / 10 K								
■ Mean TC of range	% of span	≤ 0.1 / 10 K								
Damping (display and signal)	s	0 ... 40 (adjustable)								
CE- conformity		89/336/EWG interference emission and immunity see EN 61 326 97/23/EG Pressure equipment directive (Module H)								
Shock resistance	g	100 according to IEC 60068-2-6 (mechanical shock)								
Vibration resistance	g	5 according to IEC 60068-2-27 (vibration under resonance)								
Wiring protection		Protected against reverse polarity, short circuiting and {overvoltage} on the instrument side								
Mass	kg	Approx. 0.7 {Aluminum version approx. 1.0}								

^{*}) In an oxygen version model UT-11 is not available. In an oxygen version model UT-10 is only available in gauge pressure ranges from 0.4 bar up to max. 1000 bar and with media temperatures between -20 ... +60 °C / -4 ... +140 °F.

{ } Items in curved brackets are optional extras for additional price.

Dimensions in mm

Ingress Protection IP per IEC 60 529

PBT-case
IP 65
Order code: M

cable gland
M 20x1,5
with internal terminal block
Order code: A

{locking plug
M 12x1, 4-pin
Order code: M}

see drawings

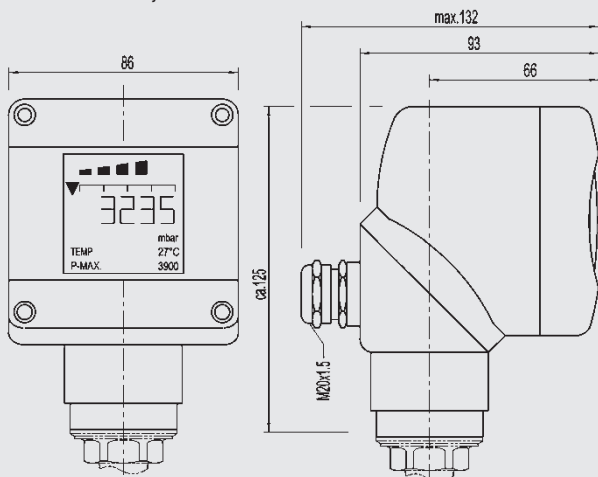

{aluminium case
IP 67
Order code: A}

{locking plug
M 12x1, 4-pin
Order code: M}

cable gland
M 20x1,5
with internal terminal block
Order code: A

see drawings

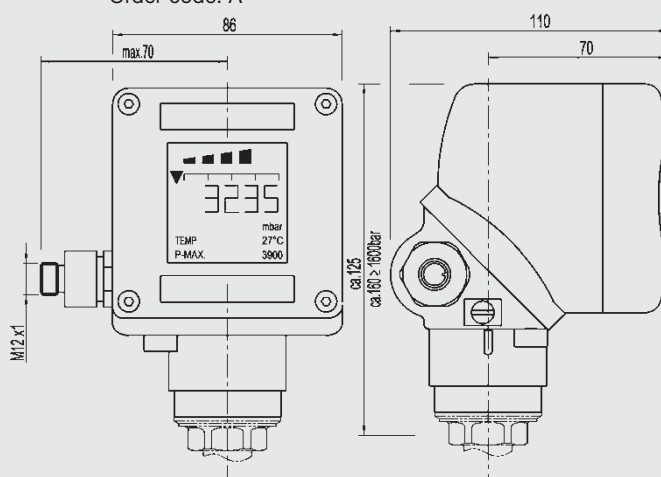

Pressure connections UT-10

G 1/2
EN 837
max. 1600 bar
Order code: GD

1/ 2 NPT
per „Nominal size for US
standard tapered pipe
thread NPT“
max. 1600 bar
Order code: ND

M 16x1,5 female ¹⁾
from 1600 bar
Order code: ML

M 20x1,5 ¹⁾
from 1600 bar
Order code: MI

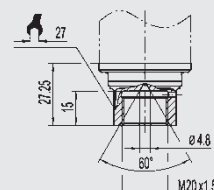
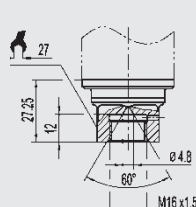
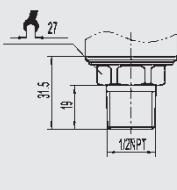
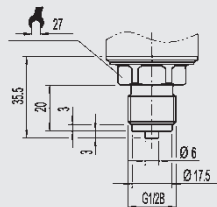

Others on request

Pressure connections UT-11

G 1
0 ... 0,4 up to 0 ... 1.6 bar
Order code: 85

G 1/2
> 1.6 bar
Order code: 86

G 1 1/2
without O-ring
0 ... 0.4 up to 0 ... 16 bar
Order code: G6

G 1
acc. EHEDG ²⁾,
0 ... 0.4 up to 0 ... 16 bar
Order code: 83
with cooling element up to 150 °C
Order code: 84

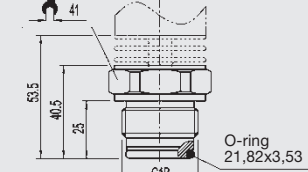
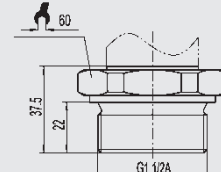
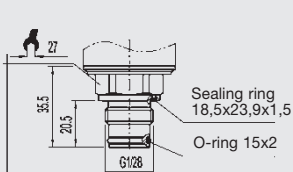
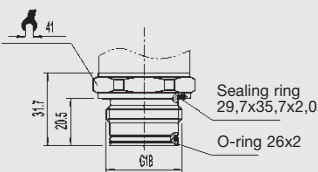

Others on request

For installation and safety instructions see the operating instructions for this product.

For tapped holes and welding sockets please see Technical Information IN 00.14 for download at www.wika.de -Service

¹⁾ The respective values for your mounting position please find in the documentation of your high-pressure equipment supplier.

²⁾ European Hygienic Equipment Design Group

{ } Items in curved brackets are optional extras for additional price.

Electrical Connection

2-wire

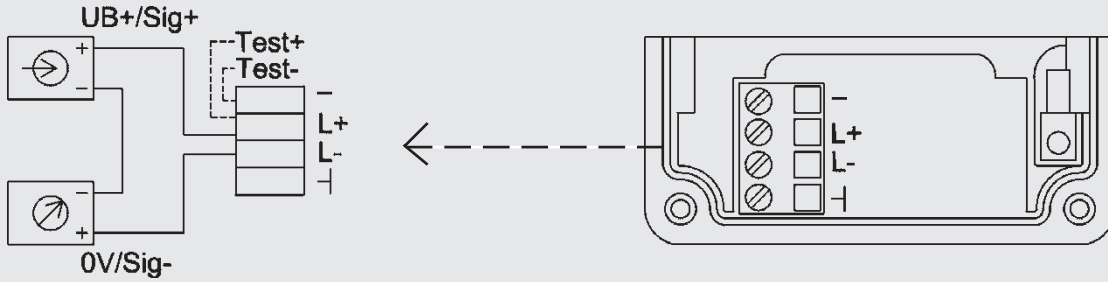

Legend:

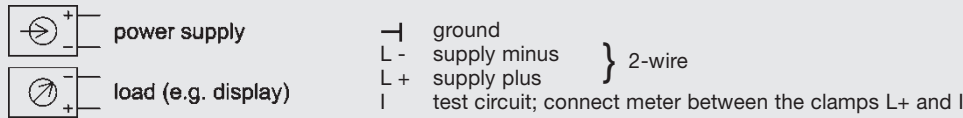

Random example of the optional display

Measuring value - display mode

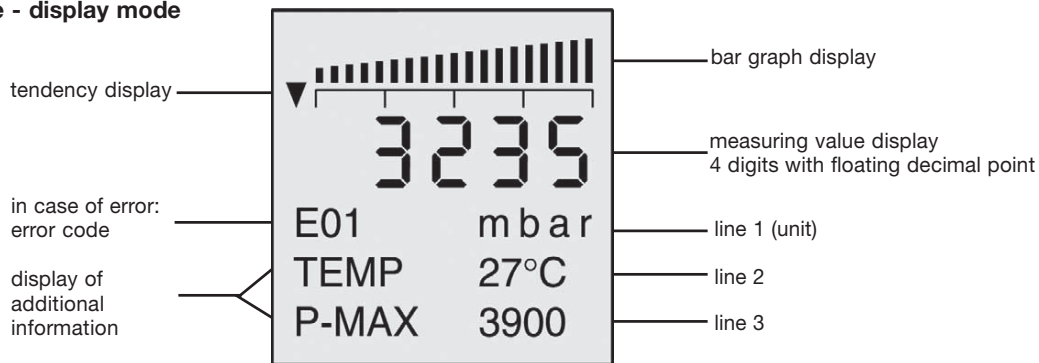

Further information

You can obtain further information (data sheets, instructions, etc.) via Internet address www.wika.de



Specifications and dimensions given in this leaflet represent the state of engineering at the time of printing. Modifications may take place and materials specified may be replaced by others without prior notice.



WIKAL Alexander Wiegand GmbH & Co. KG
 Alexander-Wiegand-Straße 30
 63911 Klingenberg/Germany
 Phone (+49) 93 72/132-0
 Telefax (+49) 93 72/132-406
 E-Mail support-tronic@wika.de
www.wika.de