

Digital Temperature Transmitter

with HART® Protocol, Rail Mounting

Electrical Temperature Measurement



Applications

- Process industry
- Machinery, plant construction

Special Features

- Functional safety (SIL 2)
- Monitoring of sensor lead resistance acc. NAMUR NE 89
- Signalling acc. NAMUR NE 43 individually configurable signalling for possible errors of the sensor system
- Configuration and write protection via password
- Configurable via
 - User friendly WIKA Configuration Software
 - HART® Communicator HC 275 / FC 375
 - Asset Management Systems



Description

The digital temperature transmitter T32 range is designed for universal use in the process industry.

Comprehensive individual configuration possibilities like, for example, type of sensor, measuring range and error signalling, high accuracy, galvanic isolation and excellent EMI protection characterize these transmitters.

The rail mounting case fits to any standard rail per DIN EN 50 022-35.

During configuration any one of 15 types of sensors can be selected. Measured temperatures are from -270 °C up to 1820 °C.

Configuration can be done by means of a HART® Communicator model HC 275 / FC 375, with FSK modem (e.g. VIATOR®) via the RS 232-C of a standard DOS PC, or with the HART functionality of a Asset Management System or DCS system.

The following sensors can be connected:

- RTDs per DIN EN 60 751, JIS C 1606, DIN 43 760 in 2, 3 and 4 wire connection, the connection-system used is configurable and ensures an optimal lead wire compensation
- thermocouples per DIN EN 60 584 resp. DIN 43 710 Cold junction compensation (CJC) is built-in, the use of an external CJC is selectable via configuration.
- resistance-sensors up to 5000 Ω in 2, 3 and 4 wire connection, configurable compensation of the connection cable
- mV-sensors up to 1200 mV

The transmitters are delivered with a basic configuration (see ordering information). Alternatively, upon request, transmitters can be delivered with a customized configuration within the given limits.

Also available as head mounting version: model T32.10, see data sheet TE 32.01.

Specifications

Model T32.30

Input	configurable: type of sensor and measuring range	max. measuring range	minimum measuring span
RTDs	Pt100 ($\alpha = 0,00385$) DIN EN 60 751	-200 ... + 850 °C ¹⁾	10 K or 3,8 Ω , whichever is greater
	JPt100 ($\alpha = 0,003916$) JIS C 1606 (1989)	-200 ... + 500 °C	
	Ni100 DIN 43 760 (1987-09)	-60 ... + 250 °C	
thermocouples	type T, Cu-CuNi DIN EN 60 584	-270 ... + 400 °C	50 K or 2 mV, whichever is greater
	type E, NiCr-CuNi DIN EN 60 584	-270 ... +1000 °C	
	type J, Fe-CuNi DIN EN 60 584	-210 ... +1200 °C	
	type L, Fe-CuNi DIN 43 710 (1985-12)	-200 ... + 900 °C	
	type K, NiCr-Ni DIN EN 60 584	-270 ... +1372 °C	
	type N, NiCrSi-NiSi DIN EN 60 584	-270 ... +1300 °C	
	type U, Cu-CuNi DIN 43 710 (1985-12)	-200 ... + 600 °C	
	type R, PtRh-Pt DIN EN 60 584	-50 ... +1768 °C	
	type S, PtRh-Pt DIN EN 60 584	-50 ... +1768 °C	
	type B, PtRh-PtRh DIN EN 60 584	0 ... +1820 °C	
resistance sensor		0 ... 700 Ω / 0 ... 5000 Ω	4 Ω up to 32 Ω
mV-sensor		-400 ... +1200 mV	4 mV up to 32 mV
signalling of sensor error		configurable (up scale, down scale, customer specific)	
RTDs / resistance sensor			
measuring deviation per DIN EN 60770, 23 °C \pm 5 K			
RTDs	MV \leq 200 °C	\pm 0.08 K	
	MV > 200 °C	\pm (0.08 K + 0.01 % (MV - 200 K))	
resistance sensor		\pm 0.03 Ω or 0.01 % MV , whichever is greater	
temperature coefficient T_c ²⁾	RTDs	\pm (0.05 K + 0.015 % MV) / 10 K T_a	
	resistance sensor	\pm (0.01 Ω + 0.01 % MV) / 10 K T_a	
sensor current		approx. 0.2 mA	
lead wire connection		configurable: 2 wire , 3 wire , 4 wire	
connection leads	effect	\pm 0.02 Ω / 10 Ω	
	max. permissible resistance	30 Ω each wire, 3 wire symmetric	
monitoring NAMUR NE 89 (Pt 100, 4 wire), i.e. sensor burn out is signalled if:		$R_{L_2} + R_{L_3} > 128 \Omega \pm 0.1 \Omega$ with hysteresis $12 \Omega \pm 0.1 \Omega$	
		$R_{L_1} + R_{L_4} + R_{Pt100} > 14.5 k\Omega \pm 30 \%$ with hysteresis $750 \Omega \pm 20 \%$	
thermocouples / mV-sensor			
measuring deviation per DIN EN 60770, 23 °C \pm 5 K			
type T, L, U	-150 °C < MV \leq 0 °C	\pm (0.25 K + 0.15 % MV)	
	MV > 0 °C	\pm (0.25 K + 0.015 % MV)	
E, J, K, N	-150 °C < MV \leq 0 °C	\pm (0.4 K + 0.2 % MV)	
	MV > 0 °C	\pm (0.4 K + 0.03 % MV)	
R, S	50 °C < MV \leq 400 °C	\pm (1.2 K + 0.1 % MV - 400 K)	
	400 °C < MV \leq 1600 °C	\pm (1.2 K + 0.015 % MV - 400 K)	
B	400 °C < MV \leq 1000 °C	\pm (1.3 K + 0.25 % MV - 1000 K)	
	MV > 1000 °C	\pm 1.3 K	
mV-sensor		\pm (10 μ V K + 0.03 % MV)	
temperature coefficient T_c ²⁾	type T, L, U	MV > -150 °C	\pm (0,1 K + 0,02 % MW) / 10 K T_a
	E, J, K, N	MV > -150 °C	\pm (0,1 K + 0,035 % MW) / 10 K T_a
	R, S	50 °C < MV \leq 1600 °C	\pm (0,3 K + 0,025 % MW - 400 K) / 10 K T_a
	B	400 °C < MV \leq 1000 °C	\pm (0,4 K + 0,02 % MW - 1000 K) / 10 K T_a
		MV > 1000 °C	\pm (0,4 K + 0,02 % MW - 1000 K) / 10 K T_a
mV-sensor		\pm (2 μ V + 0,03 % MW) / 10 K T_a	
additional error of cold junction compensation ³⁾ at 23 °C \pm 5 K		\pm 0.8 K	
temperature coefficient T_c ²⁾ of cold junction compensation ³⁾		\pm 0.1 K / 10 K T_a	
connection leads	effect	\pm 0.1 μ V / 10 Ω	
	max. permissible resistance	250 Ω each wire	
monitoring NAMUR NE 89 (Pt 100, 4 wire), i.e. sensor burn out is signalled if:		$R_{L_1} + R_{L_4} + R_{thermocouple} > 14.5 k\Omega \pm 30 \%$ with hysteresis $750 \Omega \pm 20 \%$	

MV measuring value (temperature measuring values in °C)
 R_{Lx} lead resistance at terminal X
 T_a ambient temperature
 T_c temperature coefficient

1) extended up to 1000 °C
 2) between the standard range of ambient temperature $-25 \text{ °C} \leq T_a \leq +70 \text{ °C}$
 3) only with thermocouple

Analogue output for measuring range	configurable: 4 ... 20 mA or 20 ... 4 mA, 2 wire design		
with type of sensor RTDs	linear to temperature per DIN EN 60 751 / JIS C 1606 / DIN 43760 : 1987-09		
with type of sensor thermocouple	linear to temperature per DIN EN 60 584 / DIN 43 710 : 1985-12		
by simulation mode	independent from input signal, simulation value configurable from 3.5 mA up to 22.5 mA		
output limits configurable			
application specification	lower limit:	from 3.6 mA	up to 4.0 mA
	upper limit:	from 20.0 mA	up to 21.5 mA
NAMUR NE 43	lower limit:	3.8 mA	upper limit: 20.5 mA
not active	lower limit:	3.6 mA	upper limit: 21.5 mA
measuring deviation per DIN EN 60 770, 23 °C ± 5 K	± 0.04 % of measuring span		
temperature coefficient T_C 1)	± 0.1 % of measuring span / 10 K T_a		
rising time t_{90}	approx. 0.5 s		
measured value update	approx. 3 / s		
damping	configurable: off or 1 s up to 60 s		
load R_A	$R_A \leq (U_B - 12 V) / 0.0225 A$ with R_A in Ω and U_B in V		
load effect	no measurable effect		
power supply effect	no measurable effect		
Total measuring deviation	sum of input + output per DIN EN 60770, 23 °C ± 5 K		
Signalling at analogue output	with sensor error and internal malfunction		
NAMUR NE 43	down scale	< 3.6 mA (3.5 mA with basic configuration)	
	up scale	> 21.0 mA (21.5 mA with basic configuration)	
configurable	down scale	3.5 mA up to 12 mA	
	up scale	12 mA up to 22.5 mA	
Power supply U_B			
model T32.30.000 (without Ex-protection)	DC 12 ... 42 V		
model T32.30.002 (with Ex, intrinsically safe ia)	DC 12 ... 30 V		
model T32.30.006 (with Ex-protection per CSA)	DC 12 ... 30 V		
model T32.30.009 (with Ex, energy-limited and non sparking)	DC 12 ... 40 V		
input power supply protection	reverse polarity		
Ex-protection per Directive 94/9/EC ATEX Intrinsically Safe per EN 50 020	EC Type Examination Certificate DMT 98 ATEX E 007 X		
model T32.30.002	II 1G EEx ia IIB / IIC T4 / T5 / T6		
permissible ambient temperature	-20 °C ... +70 °C with T4 -20 °C ... +70 °C with T5 -20 °C ... +60 °C with T6		
maximum values for connection of the current loop circuit (connections + and -)	$U_i = DC 30 V$ $C_i = 7.8 nF$	$I_i = 130 mA$ $L_i = 100 \mu H$	$P_i = 800 mW$
maximum values for connection of the sensor circuit (connections 1 up to 4)	$U_o = DC 11.5 V$ Group II B: Group II C:	$I_o = 12.3 mA$ $C_o = 11 \mu F$ $C_o = 1.6 \mu F$	$P_o = 35.2 mW$ $L_o = 1 mH$ $L_o = 1 mH$
Ex-protection, Intrinsic Safety per CSA	CSA File No. 1248412 (old: LR 105000-6)		
model T32.30.006	Intrinsically Safe: Class I, Division 1, Group A, B, C and D Non-Incendive: Class I, Division 2, Group A, B, C and D		
max. permissible ambient temperature	70 °C, 70 °C, 60 °C for T-Code T4, T5, T6 respectively		
Entity Parameters	Input Terminals (+, -)	$V_{max} = 30 Vdc$ $C_i = 7.8 nF$	$I_{max} = 130 mA$ $L_i = 0.1 mH$
	Output Terminals (1, 2, 3, 4)	$V_{oc} = 11.5 Vdc$ $C_a = 1.6 \mu F$	$I_{sc} = 12.3 mA$ $L_a = 1 mH$

R_A load

U_B loop power supply voltage, see power supply

T_a ambient temperature

T_C temperature coefficient

1) between the standard range of ambient temperature $-25^\circ C \leq T_a \leq +70^\circ C$

Ex-protection per Directive 94/9/EC energy-limited resp. non sparking equipment per EN 50 021	Type Examination Certificate DMT 99 E 088 X
model T32.30.009	II 3G EEx nL/nA IIC T4 / T5 / T6
permissible ambient temperature	-20 °C ... +70 °C with T4 -20 °C ... +70 °C with T5 -20 °C ... +60 °C with T6
maximum values for connection of the current loop circuit (connections + and -)	$U_i = DC 40 V$ $C_i = 7.8 nF$ $L_i = 100 \mu H$
maximum values for connection of the sensor circuit (connections 1 up to 4)	$U_o = DC 5.5 V$ $I_o = 0.21 mA$ $C_o = 1000 \mu F$ $L_o = 1000 mH$
Electromagnetic compatibility (EMC)	per EMC Directive 89/336/EEC EN 61326:1997 / A1:1998 and additional NAMUR NE 21 (May 93)
Ambient conditions	
ambient and storage temperature	-25 ... +70 °C
climate class	Bx (-20 ... +70 °C, 5 % up to 95 % relative humidity) DIN EN 60 654-1
maximum permissible humidity	90 % relative humidity DIN IEC 68-2-30 Var. 2
vibration	10 ... 2000 Hz 5 g DIN IEC 68-2-6
shock	DIN IEC 68-2-27 $g_N = 30$
salt fog	DIN IEC 68-2-11
Special features	
communication	HART protocol Rev. 5 inclusive burst mode, Multidrop
<p>All T32 parameters are configurable with following possibilities:</p> <ul style="list-style-type: none"> - user friendly WIKA Configuration Software, free of charge Download possible via www.wika.de - HART Communicator HC 275 / FC 375: T32 Device Description is integrated resp. upgradable with old versions - Asset Management Systems <p>AMS: completely integrated resp. upgradable with old versions Simatic PDM: completely integrated from version 5.1, upgradable with version 5.0.2 Smart Vision: upgradable by DTM per FDT 1.2 standard from SV version 4 via T32 DTM with all supporting applications with FDT 1.2 interface, such as PACTware (see Accessories page 6 DTM)</p> <p>The Configuration Set (see accessory) can be used for the direct communication via the serial interface of a PC.</p> <p>Note: Parameter, which are defined by a universally HART command (e.g. the measuring range) can be processed with all HART configuration tools in principle.</p>	
isolation voltage (input versus analogue output)	AC 1500 V, 60 s
warm-up time	approx. 5 Min. ¹⁾
power consumption with $U_b 24 V$	max. 540 mW
temperature units	configurable: K, °C, °F, °R
configuration and calibration data	permanently stored in EEPROM
testing current to monitor sensor	nom. 1 μA during testing cycle, otherwise 0 μA
self-monitoring	automatic execution of initial test after connection to power supply, thereafter monitoring due to internal malfunction
Case	rail mounting design
material	plastic
ingress protection	case IP 40 IEC 529 / EN 60 529
terminal connections	IP 20 IEC 529 / EN 60 529
cross section of terminal connections	max. 2.5 mm ²
weight	approx. 200 g
dimensions	see drawings

1) Time, after turn on, until the instrument will function within specified repeatability

Load diagram

The permissible load is dependent upon the loop power supply voltage.

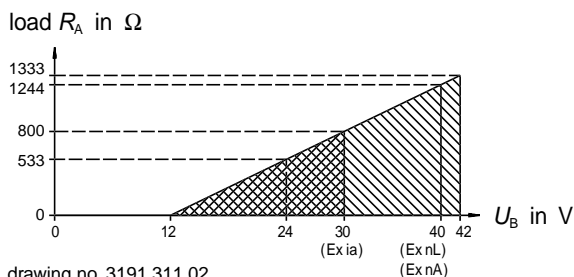

Dimensions in mm

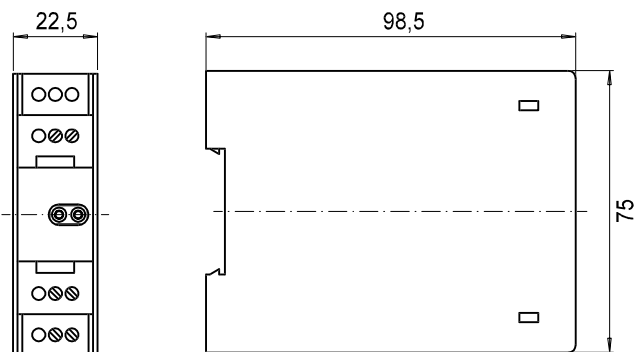

3191 303.01

Designation of terminal connectors

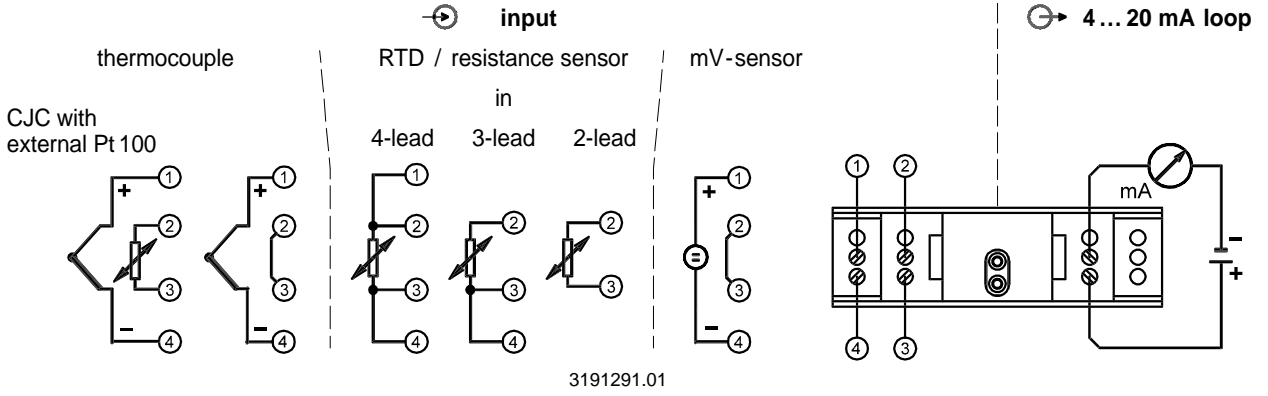

Accessory (Order No. see last page)

Field Communicator
FC375



Meriam Field Communicator
MFC4100-1



FSK modem
Model 010031 with USB interface



Wiring scheme

Following must be observed, particularly with applications in hazardous area:

- The wiring scheme
- The total of all output values of all simultaneously connected instruments (Power supply, FSK modem, HART® Communicator) must not exceed the permissible maximum values of the T32.

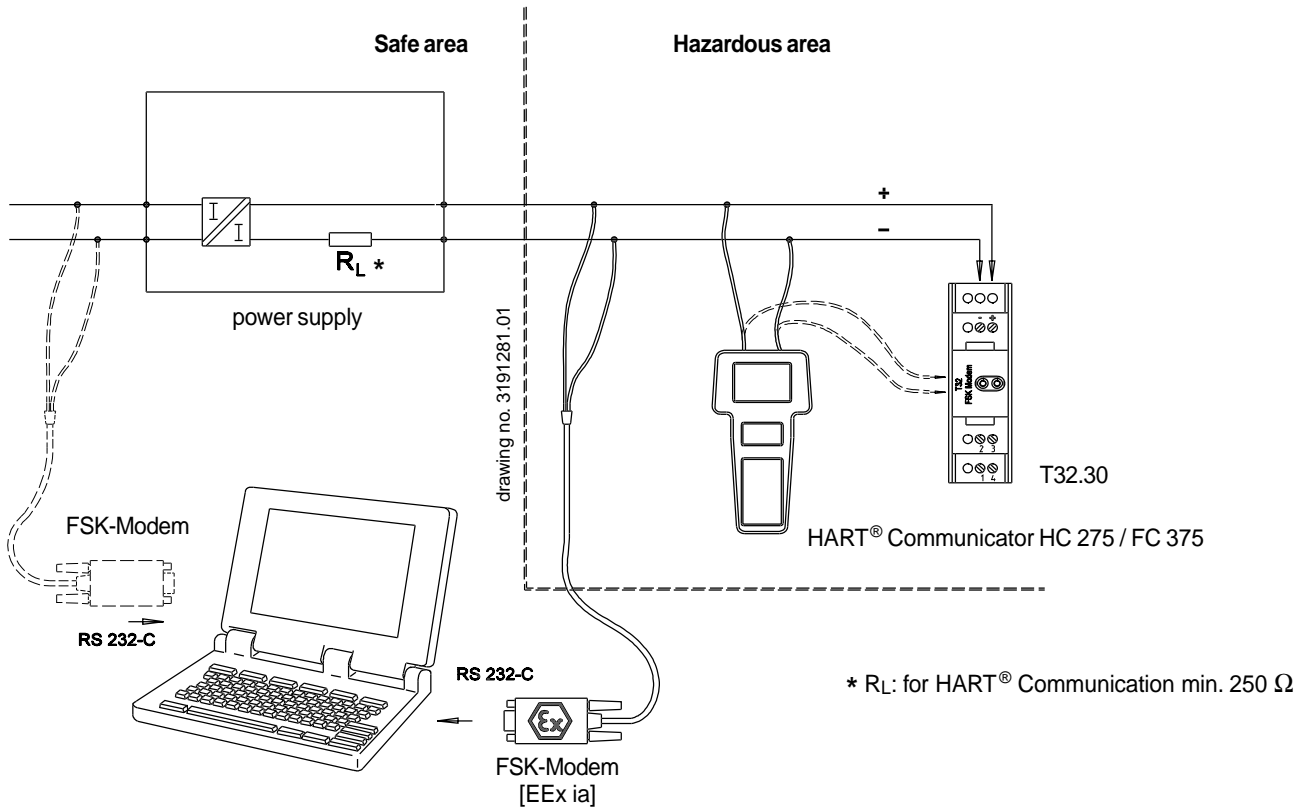

Ordering information for temperature transmitter Model T32.30

Field No.	Code	Features
Model		
1	T32.30	T32.30, rail mounting
Explosion protection		
	0	without
	2	II 1G EEx ia IIC T4/T5/T6 acc. to directive 94/9/EC (ATEX)
	6	CSA Class I, Division 1, Group A, B, C and D
2	9	II 3G EEx nL/nA IIC T4/T5/T6
Measuring range		
	GK	basic configuration 1)
3	KK	customer's specification 2) <i>please state as additional text</i>
Ambient temperature		
4	R	Standard -20 °C ... +70 °C
Additional order info		
	YES	NO
5	T	Z
		additional text <i>Please state as clearly understandable text!</i>

Order code:

1	2	3	4	5
T32.30	- 00	□	- □ R	- □

Additional text:

Accessory <i>(please order separately)</i>	Order No.
Configuration Software T32 on 3.5" disk 3)	36 33374
FSK modem model 010031 with USB interface; particularly for use with modern notebooks	110 25166
FSK modem Model 010001 with RS232 interface	79 57522
FSK modem Model 010005 with RS232 interface and explosion protection according to ATEX	24 42791
FIELD COMMUNICATOR FC375 english for HART, ATEX II 2G (1GD) EEX IA IIC T4, FM CLASS I, DIVISION1, GROUPS A,B,C AND D T4, CSA EX IA IIC NiMH Accu, with power supply 90-240 VAC, without EASY UPGRADE OPTION	22 97486
DTM Basic Collection, incl. PACTware includes DTMs for WIKA field instruments, saving and printing not possible	79 54361

- 1) Input signal: Pt 100 in 3 wire connection, Measuring range: 0 ... 150 °C, Output signal: 4 ... 20 mA, Output limits: NAMUR (lower limit: 3.8 mA upper limit: 20.5 mA), Signalling of sensor error: NAMUR down scale (3.5 mA), Damping: off, Mains: 50 Hz, Write protection: not active
- 2) Please pay attention to the limits of measuring ranges on page 2.
- 3) Free of charge download from the [WIKAI](http://www.wika.de) Homepage www.wika.de

Specifications and dimensions given in this leaflet represent the state of engineering at the time of printing. Modifications may take place and materials specified may be replaced by others without prior notice.



WIKAI Alexander Wiegand GmbH & Co. KG
 Alexander-Wiegand-Straße · 63911 Klingenberg
 Tel.: (0 93 72) 132-0 · Fax: (0 93 72) 132-406
<http://www.wika.de> · E-mail: info@wika.de